

D3 Bookcase Add-on Unit

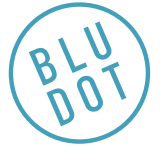

DESIGNED IN 2012

ASSEMBLY NOTES | REV 00

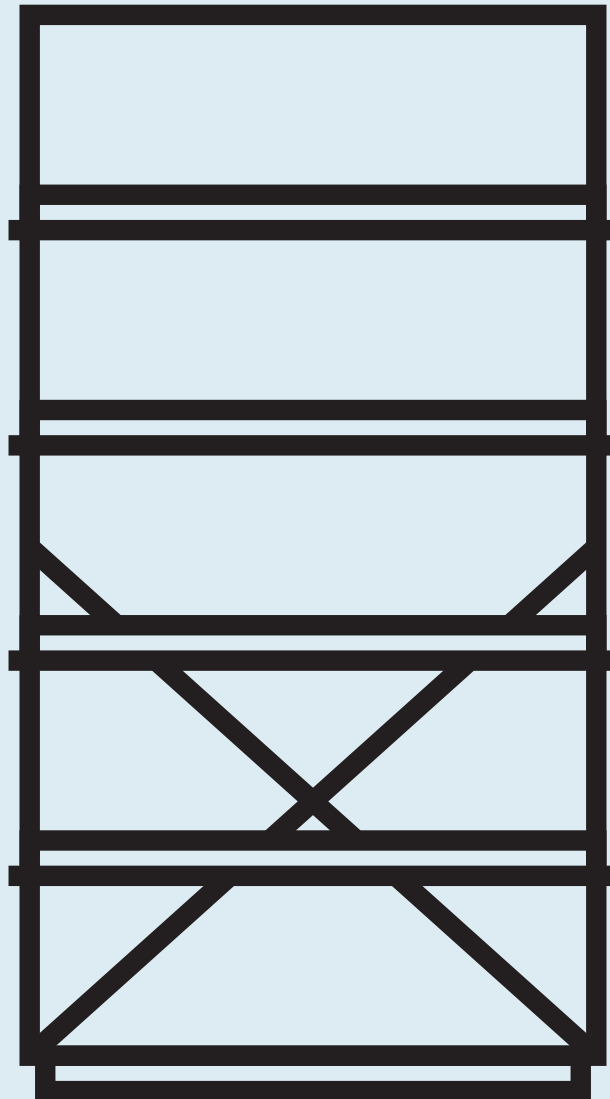

NEED A HAND?

Contact us at service@bludot.com or
844.425.8368 for assistance.

@BLUDOT

We design all our pieces in our Minneapolis studio. Follow
along on Instagram for some sneak peeks into the process.

Parts & Hardware



QTY 12
PT. 5012



QTY 8
PT. 5013

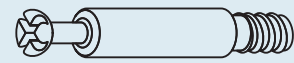

QTY 12
PT. 5002

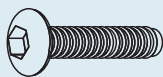

QTY 2
PT. 1698

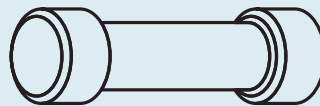

QTY 8
PT. 8012

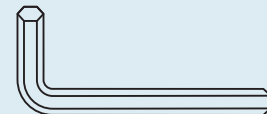

QTY 1
PT. 9004

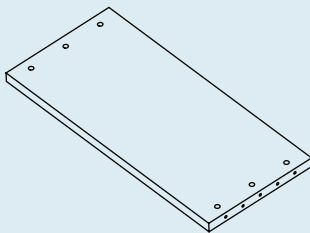

QTY 1
Top Panel

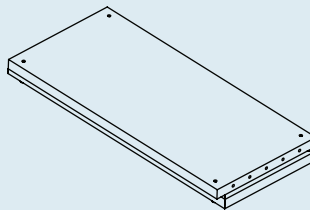

QTY 1
Bottom Panel

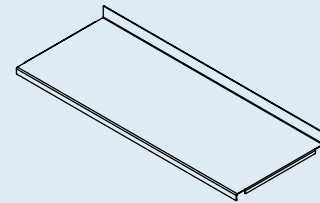

QTY 4
Shelf Panel

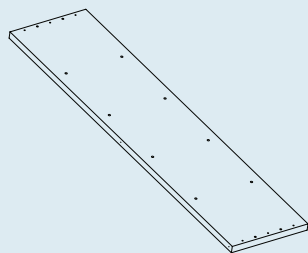

QTY 1
Center Panel

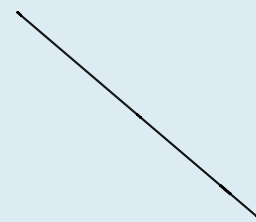

QTY 2
Brace Rod

How to use the cam lock system

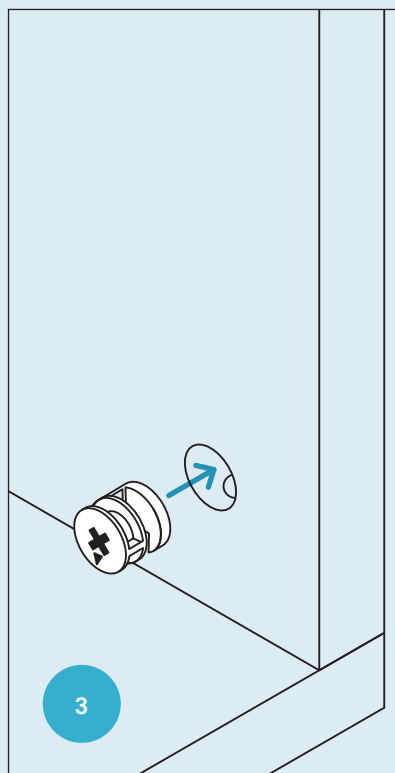
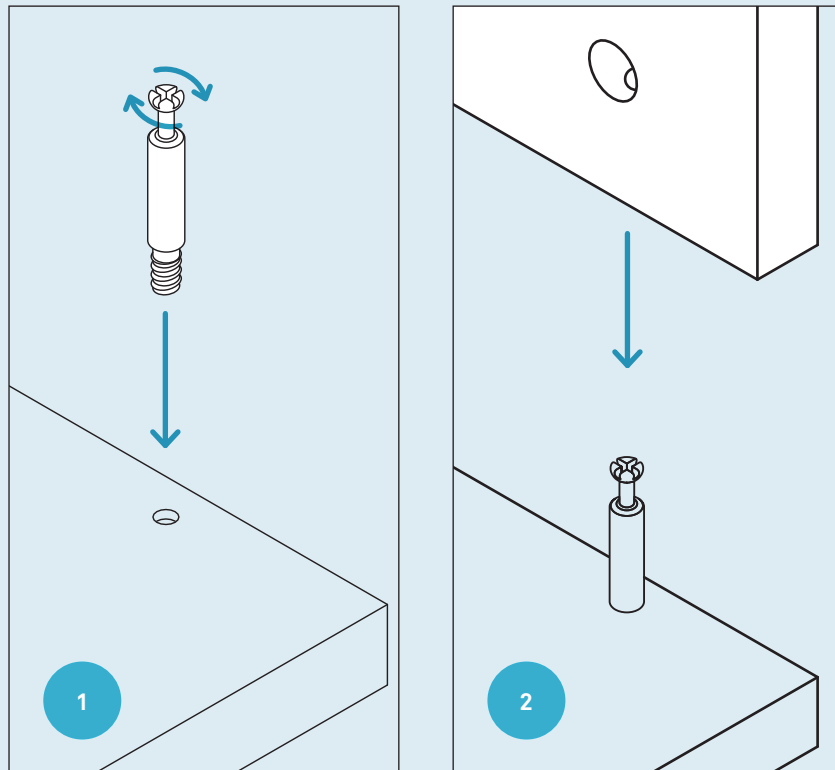

Note direction of cam arrow.

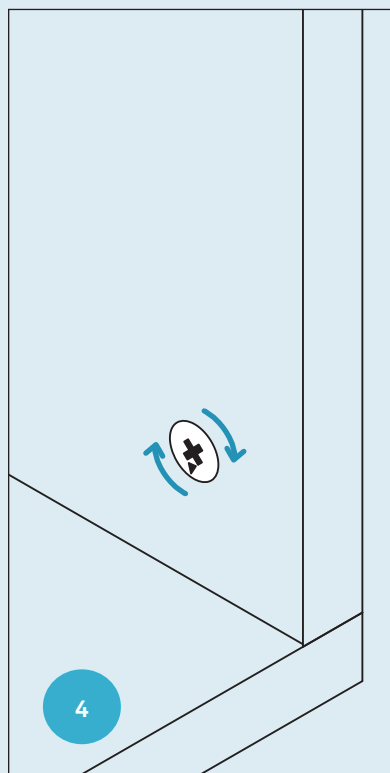

Turn cam clockwise 1/2 turn or until tight.

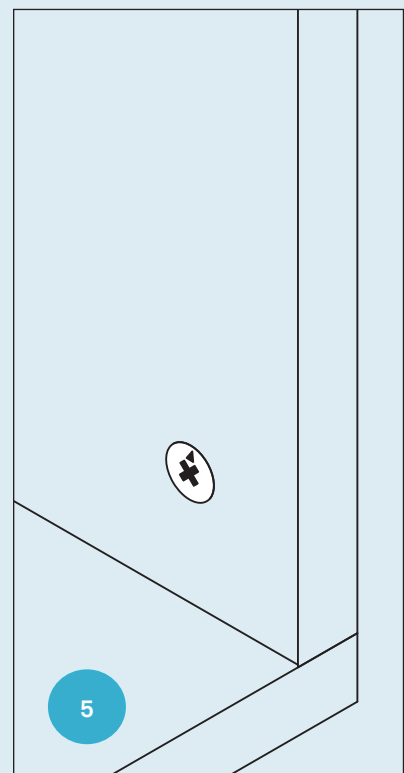

Note direction of cam arrow.

Step 01

ASSEMBLE CASE.

Assemble this bookcase on a soft, flat surface with the help of another individual.

Screw **PT. 5002** flush in the center panel.

Carefully tap **PT. 5013** into place in the center panel.

Refer to page 2 for instructions on how to use **PT. 5012** to lock hardware in place.

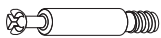
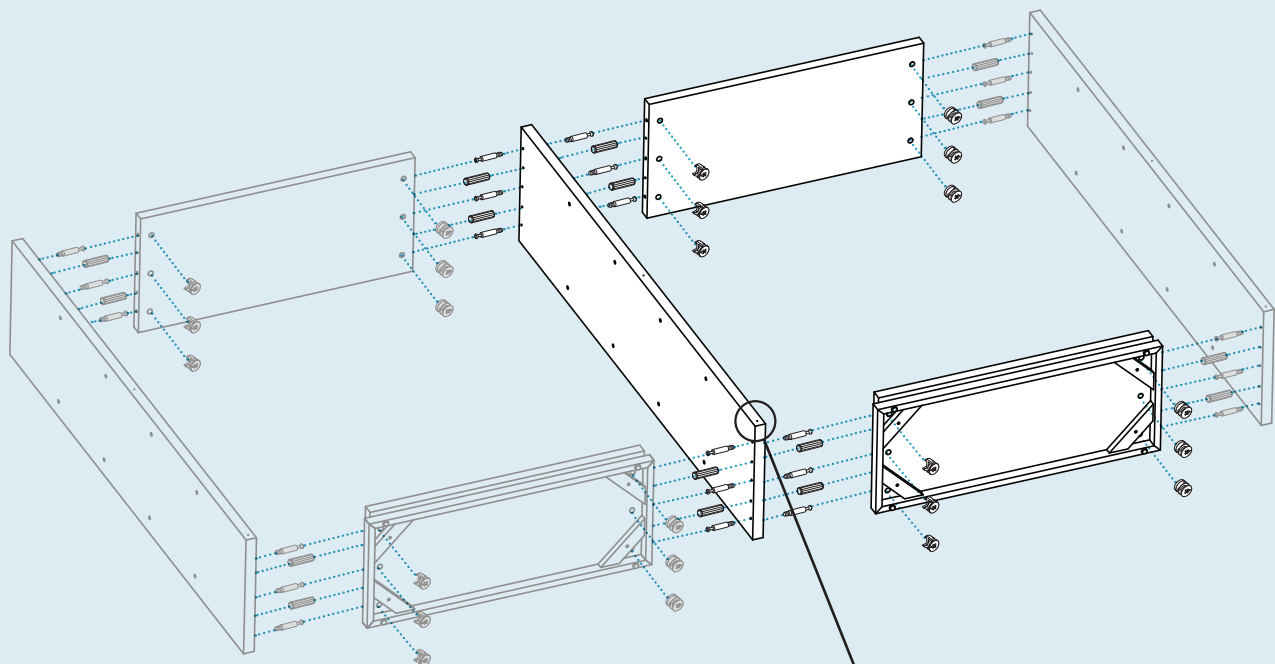

PT. 5002 x 12



PT. 5013 x 8



PT. 5012 x 12

Ensure holes on bottom corners are facing up.

Step 02

ATTACH BRACE RODS.

Attach brace rods to panels using provided hardware as shown.

Check that the case is square. Adjust rod lengths to line up with holes.

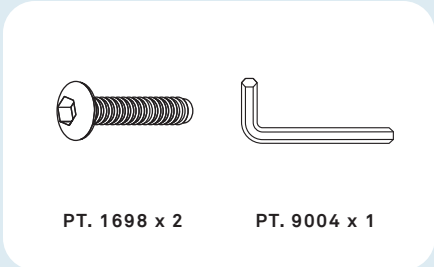
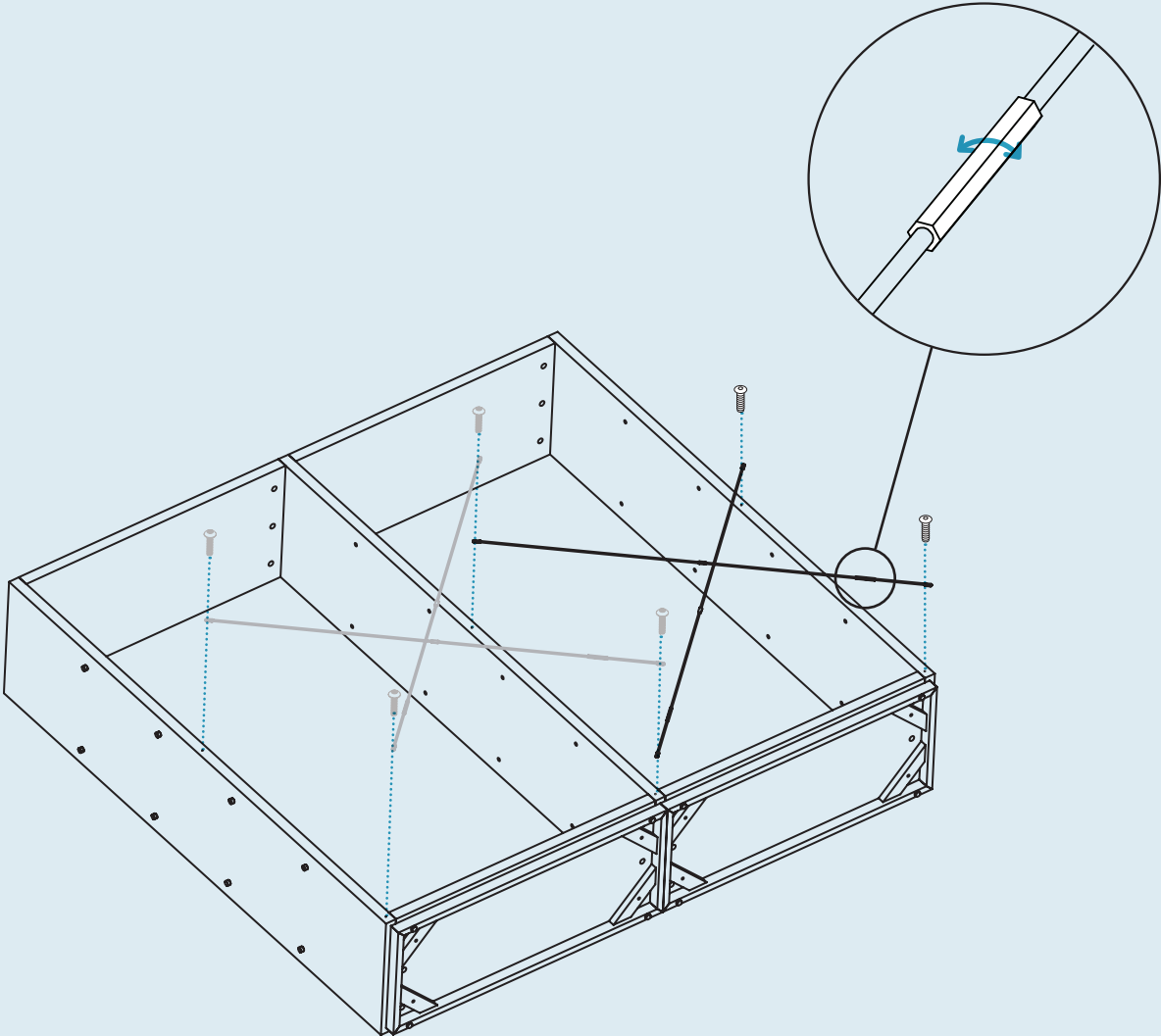

Step 03

TIGHTEN BRACE RODS.

After the brace rods are screwed down, give them a final tightening.

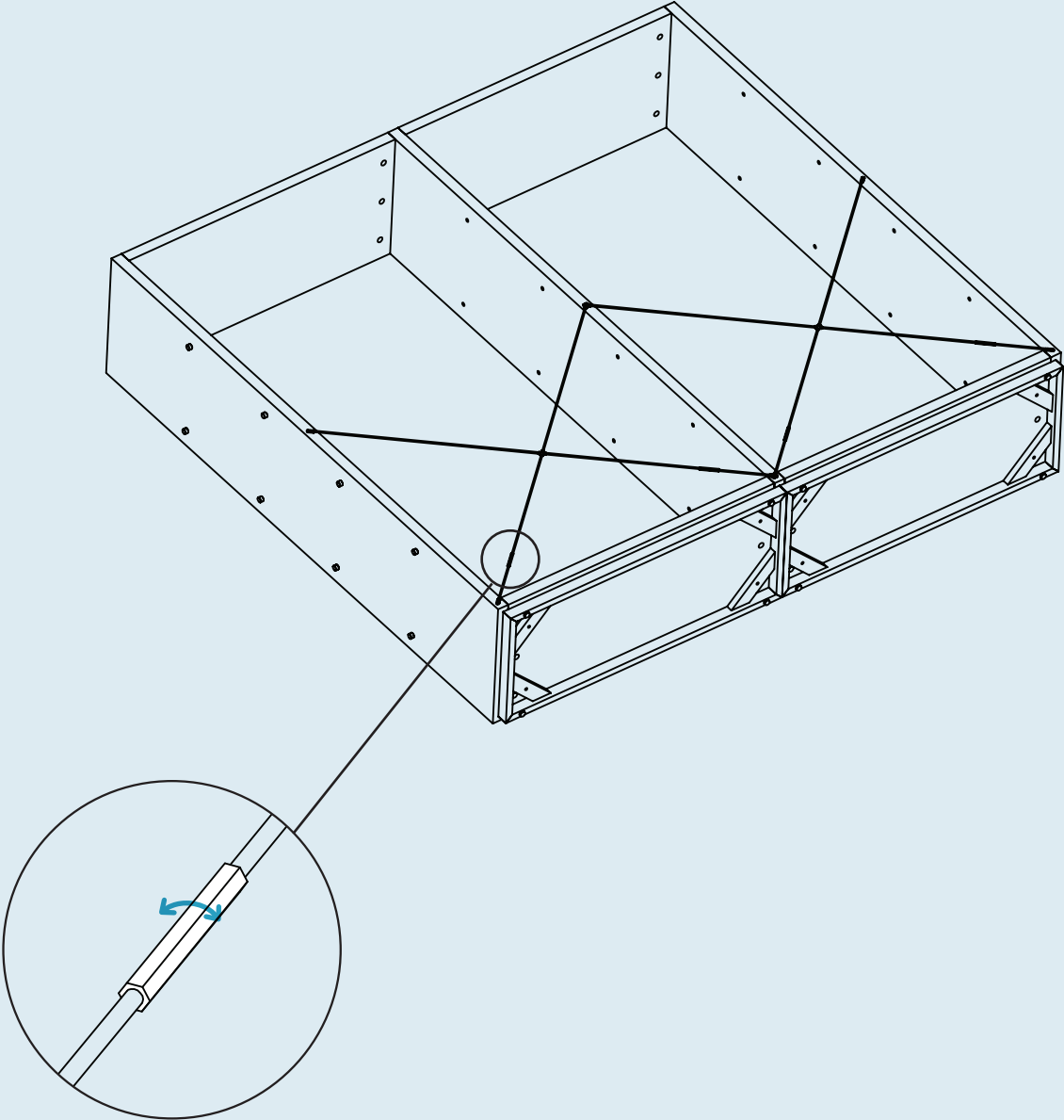

Step 04

ATTACH SHELF PINS.

Thread shelf pins into place as shown.

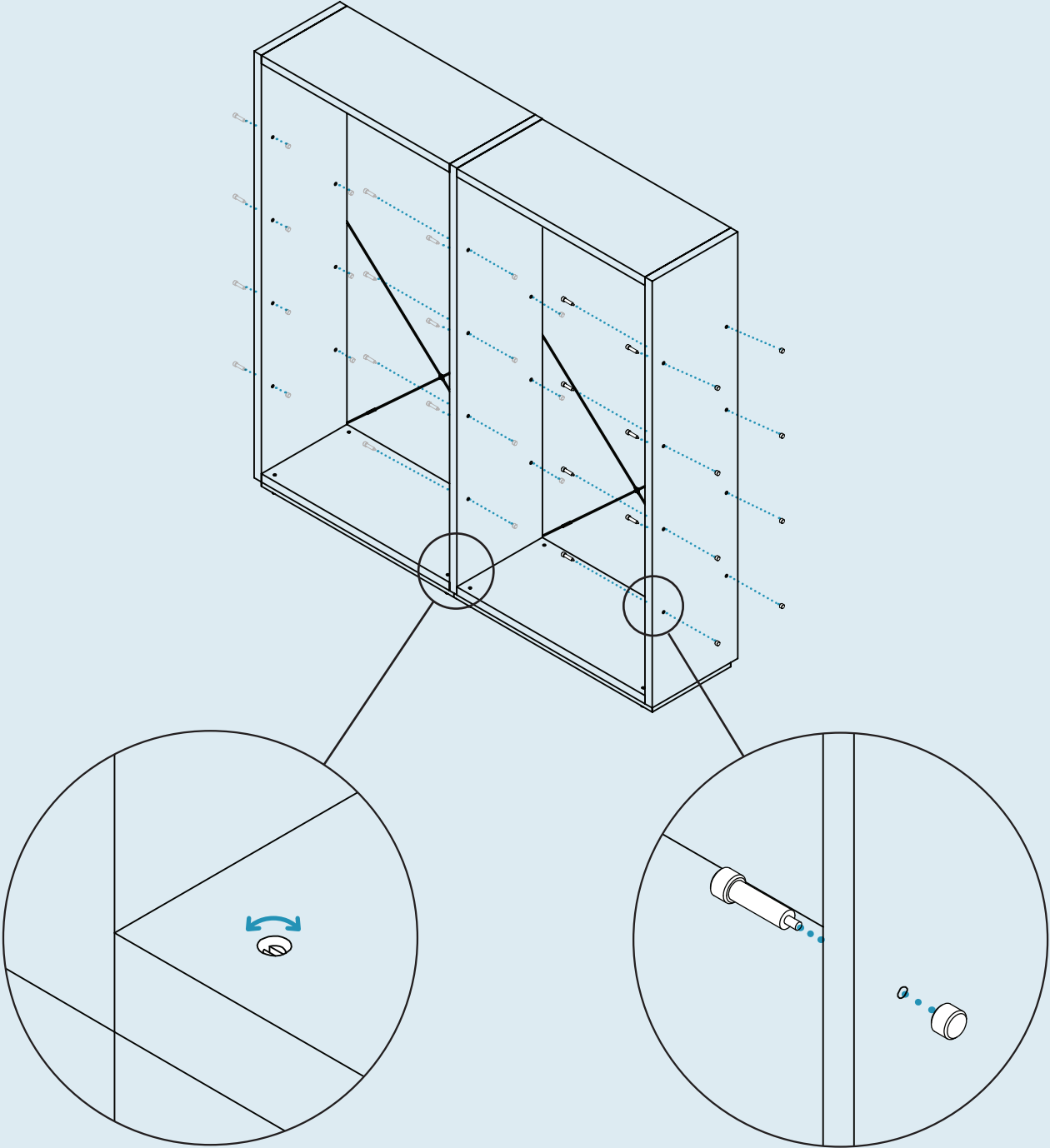

Turn to adjust the feet height to level the case.

Step 05

INSTALL SHELVES.

Place shelf panels into the case as shown.
Ensure that the case is level prior to use.

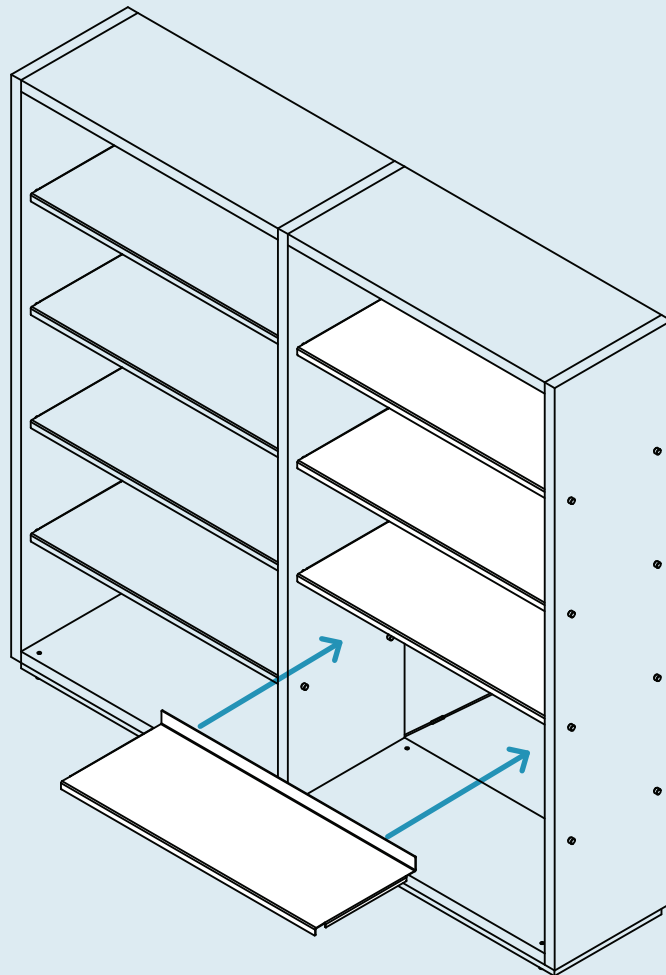

Additional Information

CLEAN

Clean with a slightly damp, soft cloth. To remove dirt and fingerprints, use a quality cleaner formulated for wood and metal furniture. Wipe completely dry with a soft cloth in the direction of the wood grain.

