

2D:3D Letter Holder



DESIGNED IN 2006

ASSEMBLY NOTES | REV 00



NEED A HAND?

Contact us at service@bludot.com or
844.425.8368 for assistance.

@BLUDOT

We design all our pieces in our Minneapolis studio. Follow
along on Instagram for some sneak peeks into the process.

Parts & Hardware

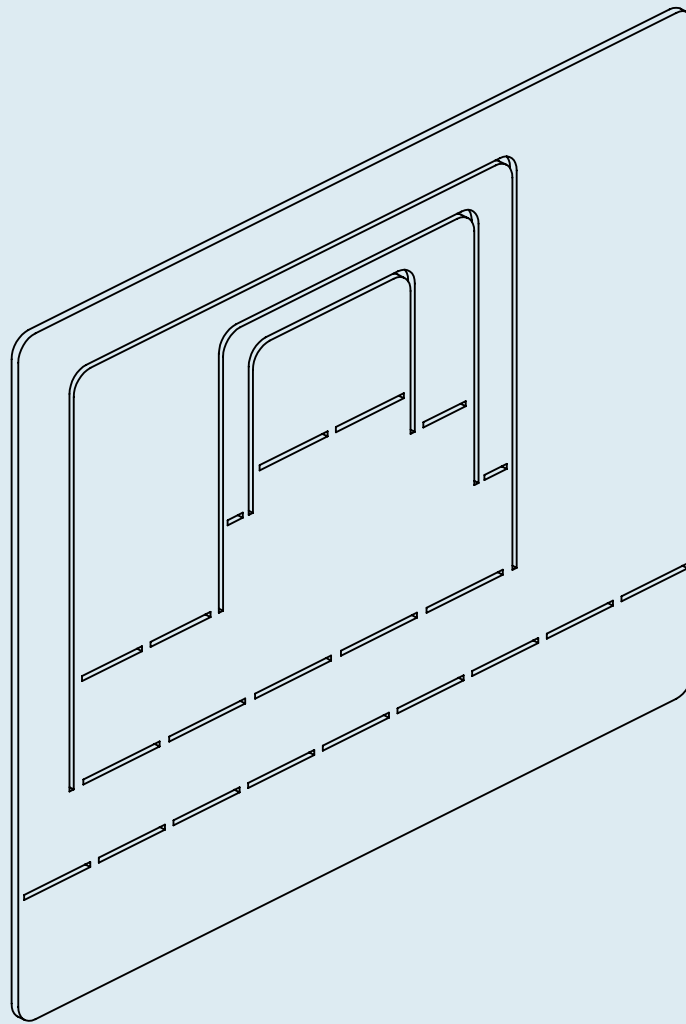

QTY

1

Letter Holder

Step 01

BEND FLAP BACK 90 DEGREES.

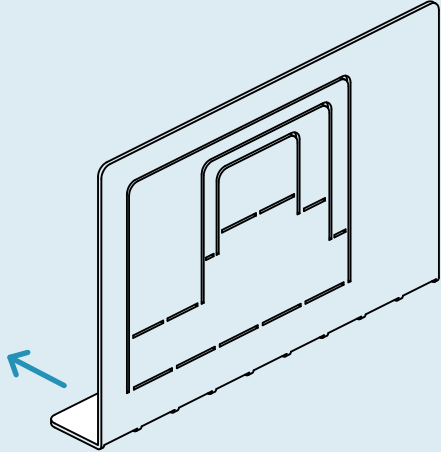

Step 02

BEND FLAPS FORWARD A LITTLE MORE THAN 90 DEGREES AS SHOWN.

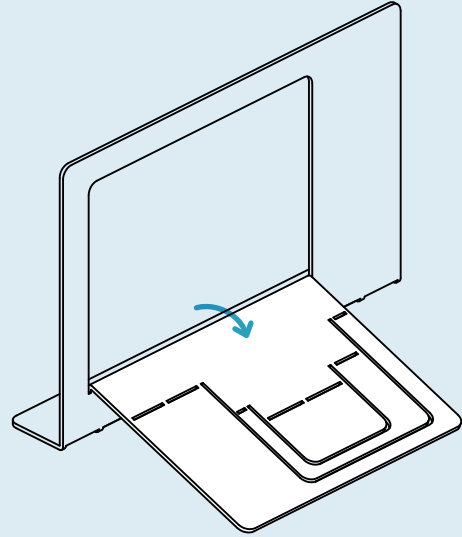

Step 03

BEND FLAP UPRIGHT AS SHOWN.

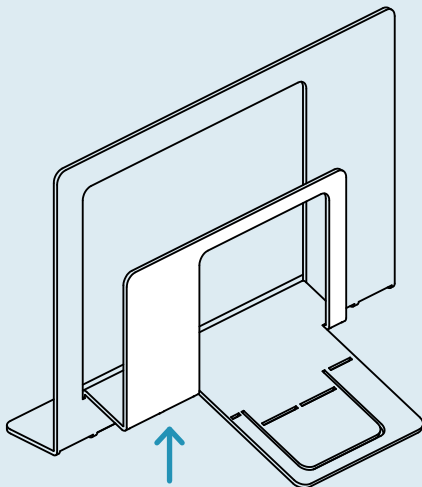

Step 04

BEND FLAP UPRIGHT AS SHOWN.

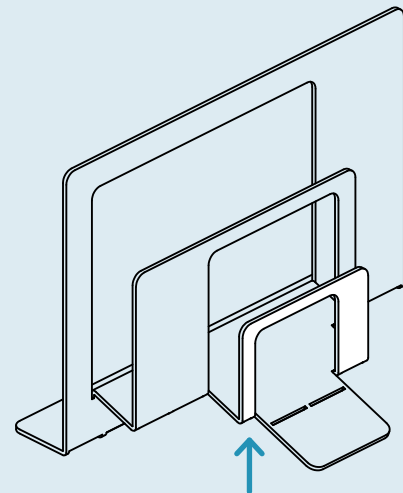

Step 05

BEND REMAINING FLAP UPRIGHT AS SHOWN.

Bend the remaining flap upright to complete assembly. Adjusted bends as needed to match side view shown.

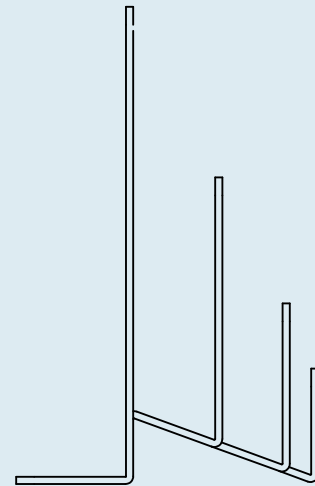
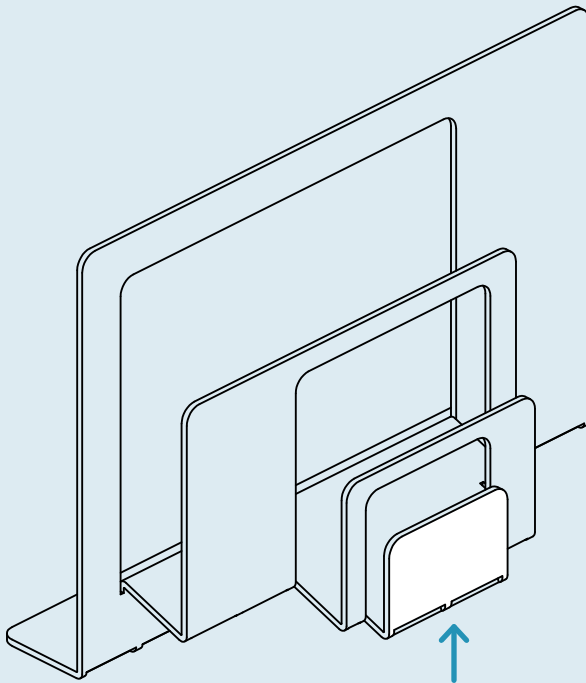

Side View

Additional Information

CLEAN

Clean with a soft cloth or sponge using a mild detergent, such as dish soap, and warm water. Wipe completely dry with a soft cloth.

